

Scientific letters

Usefulness of Genetic Diagnosis in a Woman With Hypertrophic Cardiomyopathy and the Desire for Motherhood**Utilidad del diagnóstico genético en la miocardiopatía hipertrófica de una mujer que desea ser madre****To the Editor,**

Familial heart disease is characterized by its genetic origin and the possibility of affecting several members of the same family. The most common familial heart disease is hypertrophic cardiomyopathy, with a prevalence of 1:500.¹ In recent decades, our knowledge of the molecular basis of these diseases has increased and genetic analysis has been introduced into clinical practice.^{2,3}

We present the case of a family with hypertrophic cardiomyopathy. The index patient is a 31-year-old woman diagnosed in 1995 and treated with 300 mg propranolol daily. She was admitted to our unit for the first time in 2010 with recurrent syncope. The electrocardiogram revealed signs of left ventricular hypertrophy. The echocardiogram showed an interventricular septal thickness of 27 mm, a peak pressure gradient of 70 mmHg, systolic anterior motion of the mitral valve, and grade 2 mitral regurgitation. She had a family history of sudden cardiac death: 2 maternal great-uncles and a second cousin who died at the age of 20 years while engaged in a sport. The decision was made to place an implantable cardioverter defibrillator, in accordance with the recommendations of the clinical guidelines.⁴

The patient came to the inherited heart disease team seeking preconception counseling: she had frozen pre-embryos in the United States as the result of an unsuccessful attempt at pre-embryo gestation in a third person. She was asymptomatic and had never received shocks from the implantable cardioverter

defibrillator. Her parents had never been assessed by a cardiologist and her brother had not had an echocardiogram since 1995.

After establishing the mode of inheritance, autosomal dominant, we requested an echocardiogram and cardiopulmonary exercise test to stratify the risk associated with pregnancy, and genetic testing to enable us to provide her with appropriate genetic counseling. The echocardiographic findings were an interventricular septal thickness of 32 mm, a peak pressure gradient of 60 mmHg, grade 2 mitral regurgitation, and mild pericardial effusion. In the cardiopulmonary exercise test, the patient reached a maximal oxygen consumption of 26.1 mL/kg/min (73% of the predicted value), which would not be a contraindication for pregnancy. Nevertheless, the patient was informed of the high risk of cardiac complications. Once she had given her informed consent, genetic testing was carried out for the most common sarcomeric genes (*MYBPC3*, *MYH7*, *TNNT2*, *TNNI3*, *TPM1*), and was positive for 2 mutations of the *MYBPC3* gene (NM_000257.2). One was a missense mutation, with a change in the c.13G>C;G5R nucleotide, previously reported in the literature⁵; the other variant was an insertion mutation, c.3066dupC;N1023fs+28X, that had not been reported previously, but given that it produces a change in the reading frame, which results in a truncation of the protein, we consider that it is probably involved in the pathogenesis of this heart disease.

The patient's brother was 37 years old. His electrocardiogram showed peaked T waves and he had a phenotype characteristic of hypertrophic cardiomyopathy: an interventricular septal thickness of 19 mm, with fibrosis detected by magnetic resonance imaging. The genetic test was positive for only one mutation, c.3066dupC;N1023fs+28X. Their father was 63 years old, and had hypertension, an electrocardiogram with early repolarization, and a hypertrophic cardiomyopathy of uncertain phenotype

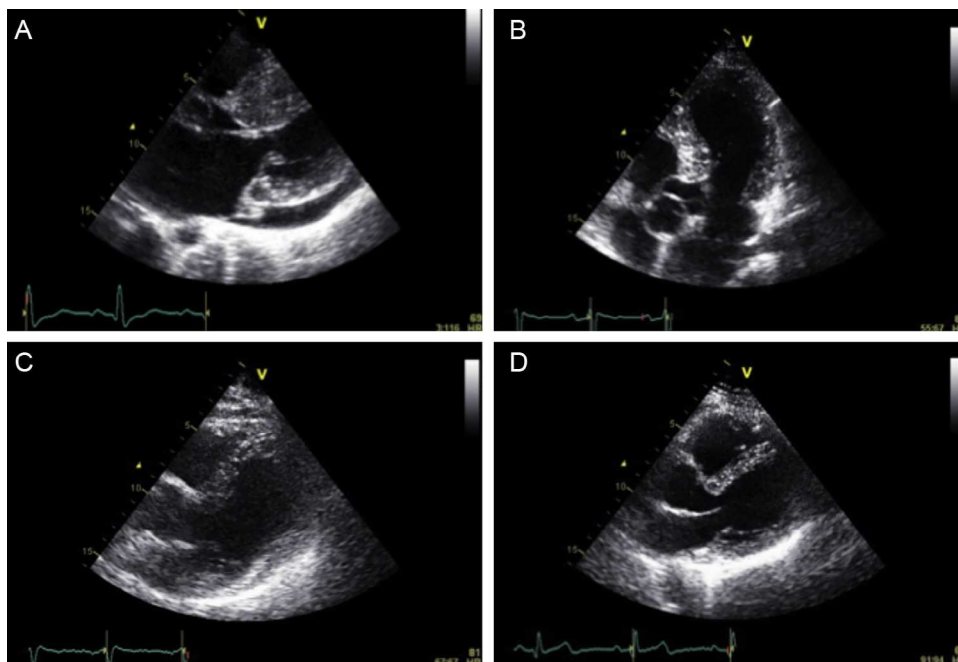

Figure 1. Echocardiograms of the family members. A: Index patient. B: Brother of the index patient. C: Father of the index patient. D: Mother of the index patient.

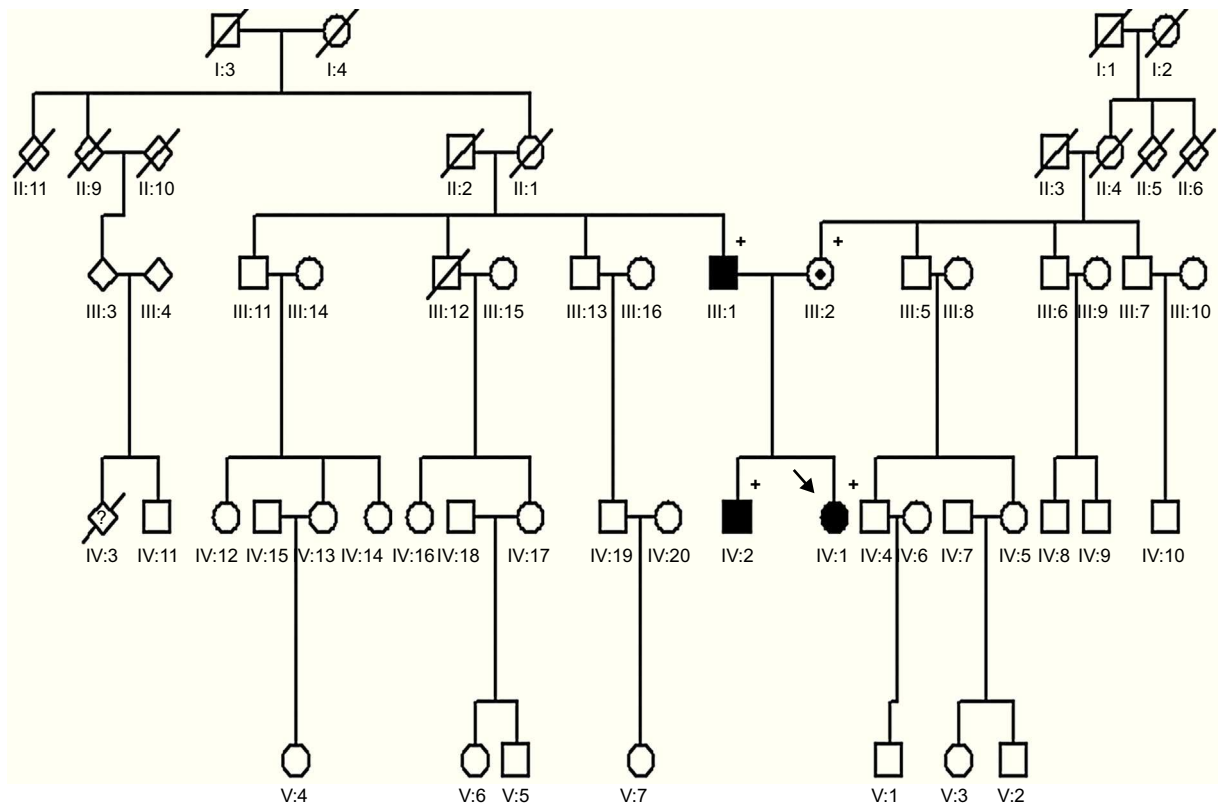

Figure 2. Family tree.

because of this earlier finding: the thickness of the interventricular septum was 16 mm and that of posterior wall was 10 mm. Genetic testing was positive for the first mutation (c.13G>C;G5R). The mother was 60 years old. Her electrocardiogram and echocardiogram were normal (interventricular septal thickness, 7 mm) (Figure 1). The genetic test was positive for the second mutation (c.3066dupC;N1023fs+28X) (Figure 2).

In short, the index patient had 2 mutations of *MYBPC3* on different alleles, because each had been transmitted by a different parent. Thus, the probability of transmitting one of the mutations is 100%, and the chance of inheriting the disease would exist in all the pre-embryos. For this reason, preimplantation diagnosis is not possible, and we advised our patient not to undergo prenatal diagnostic evaluation. In reproductive counseling, the advice that can be offered to avoid transmitting this disease to progeny is adoption or in vitro fertilization with oocyte donation.

Once the causative mutation was identified, the possibility of undertaking preimplantation diagnosis had been considered. The requirements are as follows:

- Identification of the mutation that causes the disease.
- Absence of contraindications for pregnancy and the hormone therapy administered for in vitro fertilization.
- Possibility of performing rapid genetic testing in the pre-embryos.
- Compliance with legal requirements.

Our legislation permits preimplantation diagnostic evaluation for “the detection of serious hereditary diseases, with early onset and no curative postnatal treatment offered by current scientific knowledge, for the purpose of carrying out the selection of the

unaffected pre-embryos”.⁶ The performance of preimplantation diagnostic evaluation should be reported to the corresponding health authority, which will inform the Spanish National Commission on Assisted Human Reproduction at least every 6 months. However, the law does not provide a list of the hereditary diseases considered “serious”, which results in great ambiguity concerning the diseases for which preimplantation diagnostic evaluation is allowed. As the number of requests for reproductive counseling will continue to increase, it would be advisable that the working group on cardiomyopathies of the Spanish Society of Cardiology, in collaboration with other scientific societies, create a well-defined list of hereditary diseases.

FUNDING

The present report was financed in part by the Network of Cardiovascular Centers (*Red de Centros Cardiovasculares [RECAVA]*), supported by *Instituto de Salud Carlos III*.

Eduardo Villacorta,^{a,*} Eduardo Zatarain-Nicolás,^a Lucía Fernández-Pena,^a Federico Pérez-Milán,^b Pedro L. Sánchez,^a and Francisco Fernández-Avilés^a

^a*Servicio de Cardiología, Hospital General Universitario Gregorio Marañón, Madrid, Spain*

^b*Servicio de Ginecología, Hospital General Universitario Gregorio Marañón, Madrid, Spain*

* Corresponding author:

E-mail address: evillacorta@secardiologia.es (E. Villacorta).

Available online 1 November 2013

REFERENCES

1. Maron BJ. Hypertrophic cardiomyopathy: an important global disease. *Am J Med.* 2004;116:63–5.
2. Monteforte N, Napolitano C, Priori SG. Genética y arritmias: aplicaciones diagnósticas y pronósticas. *Rev Esp Cardiol.* 2012;65:278–86.
3. Ackerman MJ, Marcou CA, Tester DJ. Medicina personalizada: diagnóstico genético de cardiopatías/canalopatías hereditarias. *Rev Esp Cardiol.* 2013;66:298–307.
4. Maron BJ, McKenna WJ, Danielson GK, Kappenberger LJ, Kuhn KJ, Seidman CE, et al. 2003 ACC/ESC Expert consensus document on Hypertrophic Cardiomyopathy: A Report of the ACC Foundation Task Force on Clinical Expert Consensus documents and the ESC Committee for Practice Guidelines. *Eur Heart J.* 2003;24:1965–91.
5. VanDriest SL, Vasile VC, Ommen SR, Will ML, Tajik AJ, Gersh BJ, et al. MYBPC mutations and compound heterozygosity in hypertrophic cardiomyopathy. *J Am Coll Cardiol.* 2004;44:1903–10.
6. Ley 14/2006, de 26 de Mayo, sobre técnicas de Reproducción Asistida. BOE núm. 126 de 27 de Mayo de 2006 [accessed 9 Jul 2013]. Available at: <http://www.boe.es/boe/dias/2006/05/27/pdfs/A19947-19956.pdf>.

<http://dx.doi.org/10.1016/j.rec.2013.07.006>

Use of Antithrombotic Therapy According to CHA₂DS₂-VASC Score in Patients With Atrial Fibrillation in Primary Care

Uso del tratamiento antitrombótico según la escala CHA₂DS₂-VASC en los pacientes con fibrilación auricular en atención primaria

To the Editor,

Traditionally, the CHADS₂ score has been employed for thromboembolic risk stratification in patients with nonvalvular atrial fibrillation (AF).¹ However, with this scoring system, the basis for decisions on antithrombotic therapy was poorly defined in a large proportion of patients with intermediate thromboembolic risk, since antiplatelet and anticoagulation therapy are considered equally valid options.¹ However, it is evident that the implications of the 2 treatments differ and that, within the group of intermediate risk patients, not all of them have the same degree of risk. In this context, the CHA₂DS₂-VASC score, which is a more complete scale since it includes other factors that modulate thromboembolic risk, enables better identification of those patients with AF who will most benefit from anticoagulation therapy² than the CHADS₂ score. In fact, the guidelines of the European Society of Cardiology recommend its use in clinical practice.² A number of studies have shown that the use of the CHA₂DS₂-VASC score enables more accurate reclassification of these patients.³ However, in routine clinical practice, the criteria for anticoagulation in accordance with this score are less well known.

The objective of this study was to determine whether there are differences in the use of antithrombotic therapy depending on the application of the CHA₂DS₂-VASC or CHADS₂ risk scores. For this purpose, we analyzed the data of the Val-FAAP study, classifying the patients according to the CHA₂DS₂-VASC score. The Val-FAAP study was a multicenter, cross-sectional trial carried out in the primary care setting, in which each investigator was required to enroll a total of 4 consecutive patients who met the following inclusion criteria: age 18 years or over, patients of

both sexes, and patients with a previous electrocardiographic diagnosis of AF.⁴

The Val-FAAP study included a total of 3287 subjects with AF (mean age, 71.9 [10.1] years; 52.3% men; 92.6% with a history of hypertension; 21.3% with heart failure; and 20.9% with ischemic heart disease). Of the overall group of patients, 4.5% had a CHADS₂ score of 0; 28.1%, a score of 1; and 67.4%, a score of 2 or higher. When the CHA₂DS₂-VASC score was used, these rates were 1.9%, 12.4%, and 85.7%, respectively. The Table indicates the percentages of patients according to the antithrombotic therapy they received and the thromboembolic risk stratification score.

The main results of our study show patient distribution according to the CHA₂DS₂-VASC score compared with that corresponding to the CHADS₂ score. In principle, this enables the identification of the patients who will benefit most from long-term anticoagulation therapy for the prevention of thromboembolic complications; according to the CHA₂DS₂-VASC score, the vast majority of patients with AF are at high thromboembolic risk. These data are in line with those reported in different populations, in which thromboembolic risk stratification has been shown to be more accurate with the CHA₂DS₂-VASC score than with the CHADS₂ score, mainly in patients with intermediate thromboembolic risk.³

Unfortunately, antithrombotic therapy is improperly applied.^{5,6} For example, more than 40% of patients with a CHADS₂/CHA₂DS₂-VASC score of 0 receive oral anticoagulation therapy and more than 30% of those with a CHADS₂/CHA₂DS₂-VASC score of 2 or higher do not. This has several implications. On the one hand, the relative lack of definition of the CHADS₂ score with respect to the embolic risk of patients with scores of 0 or 1 is not the reason for the deviation of the indication for anticoagulation from the standard guidelines, since reclassification using the CHA₂DS₂-VASC score, which is more accurate in this risk range, continues to show that the anticoagulation regimen is inadequate. On the other hand, while it is true that the risk of bleeding in patients with a CHADS₂/CHA₂DS₂-VASC score of 2 or higher has not been analyzed, it would be difficult to explain such a high rate of underuse of anticoagulation therapy by an excessive risk of

Table

Distribution of Patients (%) According to the Antithrombotic Therapy Received and Thromboembolic Risk Stratification Score

	CHADS ₂ = 0	CHA ₂ DS ₂ -VASC = 0	P	CHADS ₂ = 1	CHA ₂ DS ₂ -VASC = 1	P	CHADS ₂ ≥ 2	CHA ₂ DS ₂ -VASC ≥ 2	P
No therapy	19.2	26.2	NS	16.0	18.8	NS	12.7	13.3	NS
Antiplatelet	31.9	27.9	NS	23.2	25.9	NS	19.3	20.2	NS
Anticoagulation	46.8	44.3	NS	51.6	47.0	NS	57.0	56.2	NS
Both	2.1	1.6	NS	9.2	8.3	NS	11.0	10.3	NS

NS, not significant.